

Socket Wrench Rotary Torque Sensors

Spline Torque Sensors

>Model TRS

TRS socket wrench torque sensors are used for fast, accurate measurement of bolt or nut wrenching torque. This model operates in both directions so tightening and break-away torques can be measured. It can also be used to check the calibration of mechanical torque wrenches.

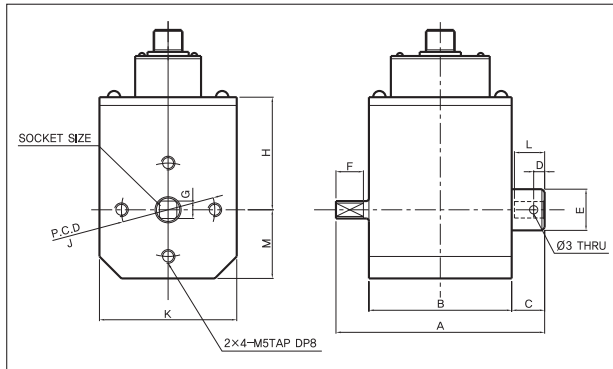
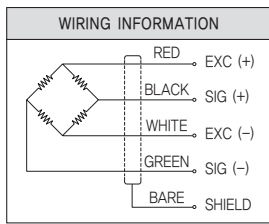

>SPECIFICATIONS

Specifications	Accuracy
Rated capacity (R.C.)	2kgf-cm~3000kgf-cm (19.61N-cm~29.42kN-cm)
Rated output (R.O.)	1.3mV/V±1%
Nonlinearity	0.3%R.O
Hysteresis	0.3%R.O
Repeatability	0.3%R.O
Terminal resistance, input	350±3.5Ω
Terminal resistance, output	350±3.5Ω
Insulation resistance	300MΩ
Temperature range, compensated	-10°C~60°C
Temperature range, safe	-20°C~70°C
Temperature effect, on zero balance	0.05% R.O/10°C
Temperature effect, on rated output	0.1% Load/10°C
Excitation recommended	10V DC
Safe overload	150% R.C.
Cable length	Ø4 Shield 3m

>DIMENSIONS TABLE (TRS)

	Socket Size	A	B	C	D	ØE	F	G	M	K	L	J	H
2, 5, 10kgf-cm (19.61N-cm, 49.03N-cm, 98.07N-cm)	1/4"	76	52	12	4	15	10	6.35	25	50	11	34	41
20, 50kgf-cm (196.1N-cm, 490.3N-cm)	3/8"	82	56	12	4	15	12.5	9.53	25	50	13	34	41
100, 300kgf-cm (980.7N-cm, 2.942kN-cm)	1/2"	96	58.5	19.5	7	20	16	12.7	31	62	17	44	42
500, 1000kgf-cm (4.903kN-cm, 9.807kN-cm)	3/4"	106	58	24	10	30	22	19.1	34	68	22	52	53
2000, 3000kgf-cm (19.61kN-cm, 29.42kN-cm)	1"	123	58	33	14	40	29.2	25.4	39	78	28	62	54

>Model TRD34

Custom torque sensor products. Torque sensor mounted on involute spline shaft. Involute splines can be changed on request

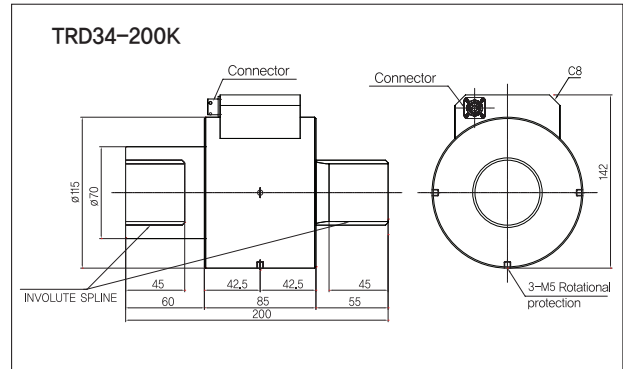

>SPECIFICATIONS

Specifications	Accuracy
Rated capacity (R.C.)	200kgf-m (1.961kN-m)
Rated output (R.O.)	1.5mV/V±1%
Nonlinearity	0.3%R.O
Hysteresis	0.3%R.O
Repeatability	0.2%R.O
Terminal resistance, input	350±50Ω
Terminal resistance, output	350±50Ω
Insulation resistance	200MΩ
Temperature range, compensated	-10°C~60°C
Temperature range, safe	-20°C~70°C
Temperature effect, on zero balance	0.05% R.O/10°C
Temperature effect, on rated output	0.1% Load/10°C
Excitation recommended	10V DC
Safe overload	120% R.C.
Cable length	Ø7, 4core, 3m

*Specifications are subject to change without notice.