

Miniature Tension Load Cells

>Model UMM, UMMA, UMMC

Compression or Tension load cell.
 These load cells are extremely small and lightweight.
 Protection Class IP66

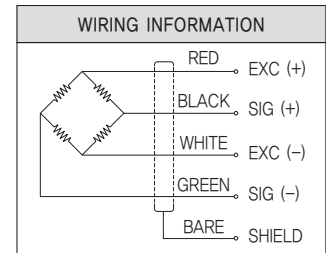
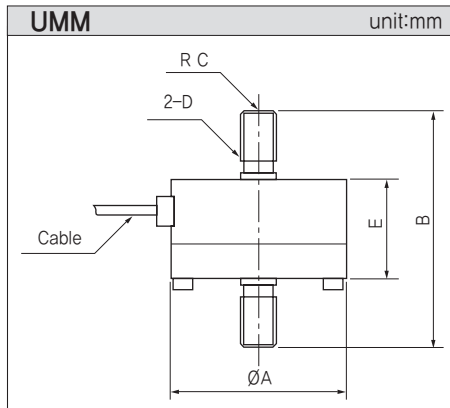
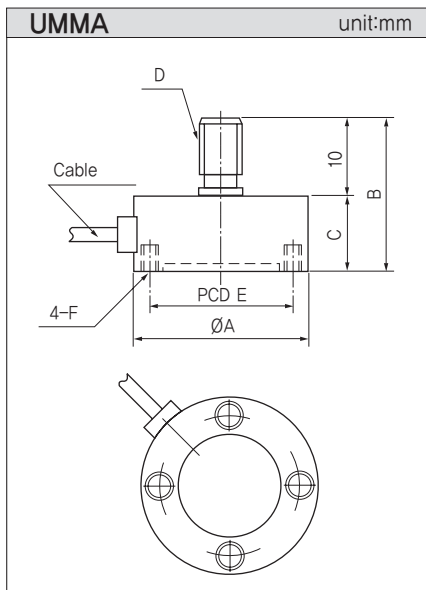
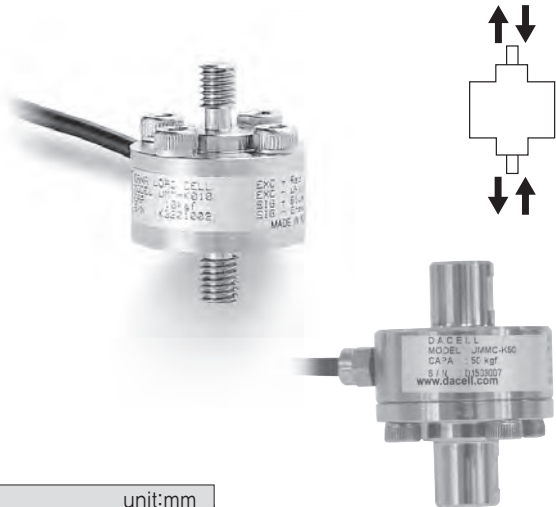

>SPECIFICATIONS

Specifications	Accuracy
Rated capacity(R.C.)	1kgf, 2kgf, 5kgf, 10kgf, 20kgf, 50kgf, 100kgf, 200kgf
Rated output(R.O.)	0.7~1.2mV/V
Nonlinearity	0.1% of R.O.
Hysteresis	0.1% of R.O.
Repeatability	0.1% of R.O.
Zero balance	±2% of R.O.
Temperature effect, on rated output	0.1% of LOAD / 10°C
Temperature effect, on zero balance	0.05% of R.O. / 10°C
Temperature range, compensated	-10~60°C
Temperature range, safe	-10~80°C
Terminal resistance input	350±30Ω
Terminal resistance output	350±2Ω
Insulation resistance bridge/case	2000MΩ
Excitation recommended	5V
Safe overload	120% R.C.
Cable length	Ø3,4core shield cable, 3m

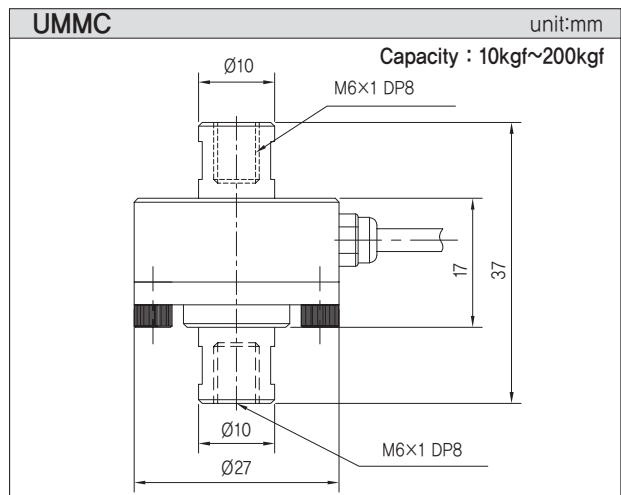

>DIMENSIONS TABLE(UMMA/UMM)

Capacity	UMMA						UMM				
	A	B	C	D	E	F	A	B	C	D	E
1kgf (9.807N)	23	20	10	M3×0.5	18	M3DP5	23	34	20	M3×0.5	14
2kgf (19.61N)	23	20	10	M3×0.5	18	M3DP5	23	34	20	M3×0.5	14
5kgf (49.03N)	23	20	10	M3×0.5	18	M3DP5	23	34	20	M3×0.5	14
10kgf (98.07N)	27	21	11	M6×1	22	M3DP5	27	37	30	M6×1	17
20kgf (196.1N)	27	21	11	M6×1	22	M3DP5	27	37	30	M6×1	17
50kgf (490.3N)	27	21	11	M6×1	22	M3DP5	27	37	30	M6×1	17
100kgf (980.7N)	27	21	11	M6×1	22	M3DP5	27	37	30	M6×1	17
200kgf (1,961kN)	27	21	11	M6×1	22	M3DP5	27	37	30	M6×1	17

*Specifications are subject to change without notice.